

# SI6700

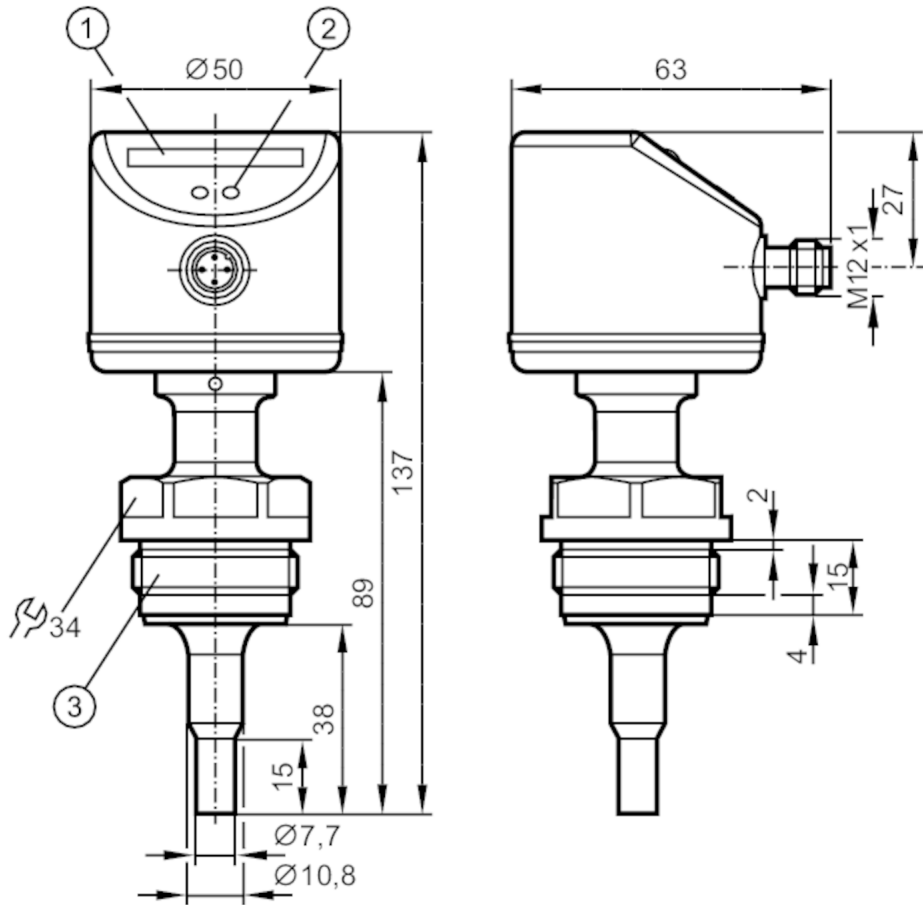

## Flow monitor

SIR11ABBFPKG/US-100-IPF



- 1 LED display
- 2 setting pushbutton
- 3 thread G1 Aseptoflex Vario



EC 1935/2004 EHEDG Certified

FCM



### Product characteristics

Number of inputs and outputs	Number of digital outputs: 1
Process connection	G 1 Aseptoflex Vario

### Application

System	gold-plated contacts
Application	hygienic systems
Medium temperature [°C]	-25...95; (for SIP process: ...140 °C)
Pressure rating [bar]	30

### Liquids

Application	hygienic systems
Medium temperature [°C]	-25...95; (for SIP process: ...140 °C)

### Gases

Medium temperature [°C]	-25...95; (for SIP process: ...140 °C)
-------------------------	--

### Electrical data

Operating voltage [V]	19...36 DC
-----------------------	------------

# SI6700



## Flow monitor

SIR11ABBFPKG/US-100-IPF

Current consumption	[mA]	< 60
Protection class		III
Reverse polarity protection		yes
Power-on delay time	[s]	10
<b>Inputs / outputs</b>		
Number of inputs and outputs		Number of digital outputs: 1
<b>Outputs</b>		
Total number of outputs		1
Output signal		switching signal
Electrical design		PNP
Number of digital outputs		1
Output function		normally open / closed; (configurable)
Max. voltage drop switching output DC	[V]	2.5
Permanent current rating of switching output DC	[mA]	250
Short-circuit protection		yes
Type of short-circuit protection		yes (non-latching)
Overload protection		yes
<b>Measuring/setting range</b>		
Probe length L	[mm]	38
<b>Liquids</b>		
Setting range	[cm/s]	3...300
Greatest sensitivity	[cm/s]	3...100
<b>Gases</b>		
Setting range	[cm/s]	200...3000
Greatest sensitivity	[cm/s]	200...800
<b>Accuracy / deviations</b>		
Repeatability	[cm/s]	1...5
Note on repeatability		for water 5...100 cm/s; 25 °C Factory setting
Temperature drift	[cm/s x 1/K]	0.1; (for water 5...100 cm/s; 10...70 °C)
Max. temperature gradient of medium	[K/min]	300
Switch point accuracy	[cm/s]	± 2...± 10; (for water 5...100 cm/s; 25 °C; Factory setting)
Hysteresis	[cm/s]	2...5; (for water 5...100 cm/s; 25 °C; Factory setting)
<b>Reaction times</b>		
Response time	[s]	1...10
<b>Liquids</b>		
Response time	[s]	1...10
<b>Gases</b>		
Response time	[s]	1...10

# SI6700



## Flow monitor

SIR11ABBFPKG/US-100-IPF

Software / programming		
Adjustment of the switch point		pushbuttons
Operating conditions		
Ambient temperature	[°C]	-25...60
Protection		IP 67; IP 69K
Tests / approvals		
EMC	EN 61000-4-2 ESD	4 kV CD / 8 kV AD
	EN 61000-4-3 HF radiated	10 V/m
	EN 61000-4-4 Burst	2 kV
	EN 61000-4-6 HF conducted	10 V
Shock resistance	DIN IEC 68-2-27	50 g (11 ms)
Vibration resistance	DIN EN 60068-2-6	10 g (55...2000 Hz)
MTTF	[years]	298
Mechanical data		
Weight	[g]	433.5
Material		stainless steel (1.4404 / 316L); PC; PBT-GF20; EPDM/X; sealing: FKM
Materials (wetted parts)		stainless steel (1.4435 / 316L); surface characteristics: Ra < 0,4 / Rz 4
Process connection		G 1 Aseptoflex Vario
Installation length EL	[mm]	54.8
Displays / operating elements		
Display	Function	10 x LED, three-color
Remarks		
Pack quantity		1 pcs.
Electrical connection		
Connector: 1 x M12; coding: A; Contacts: gold-plated		
		

# SI6700



## Flow monitor

SIR11ABBFPKG/US-100-IPF

### Connection

