

SI6800

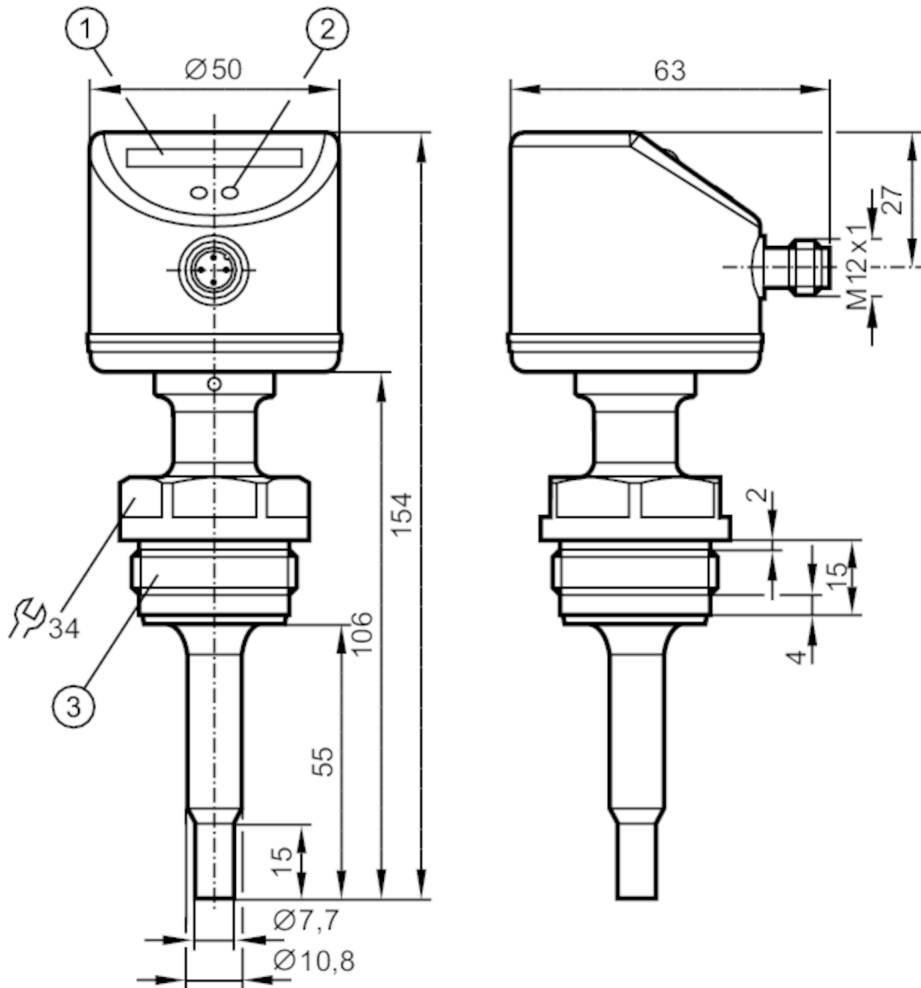

Flow monitor

SIR11ABBFPKG/US-100-IPF



- 1 LED display
- 2 setting pushbutton
- 3 thread G1 Aseptoflex Vario



Product characteristics

| | |
|------------------------------|------------------------------|
| Number of inputs and outputs | Number of digital outputs: 1 |
| Process connection | G 1 Aseptoflex Vario |

Application

| | |
|--|--|
| System | gold-plated contacts |
| Application | hygienic systems |
| Medium temperature [°C] | -25...95; (for SIP process: ...140 °C) |
| Pressure rating [bar] | 30 |
| MAWP (for applications according to CRN) [bar] | 30 |

Liquids

| | |
|-------------------------|--|
| Application | hygienic systems |
| Medium temperature [°C] | -25...95; (for SIP process: ...140 °C) |

SI6800



Flow monitor

SIR11ABBFPKG/US-100-IPF

| | | |
|---|--------------|--|
| Gases | | |
| Medium temperature | [°C] | -25...95; (for SIP process: ...140 °C) |
| Electrical data | | |
| Operating voltage | [V] | 19...36 DC |
| Current consumption | [mA] | < 60 |
| Protection class | | III |
| Reverse polarity protection | | yes |
| Power-on delay time | [s] | 10 |
| Inputs / outputs | | |
| Number of inputs and outputs | | Number of digital outputs: 1 |
| Outputs | | |
| Total number of outputs | | 1 |
| Output signal | | switching signal |
| Electrical design | | PNP |
| Number of digital outputs | | 1 |
| Output function | | normally open / closed; (configurable) |
| Max. voltage drop switching output DC | [V] | 2.5 |
| Permanent current rating of switching output DC | [mA] | 250 |
| Short-circuit protection | | yes |
| Type of short-circuit protection | | yes (non-latching) |
| Overload protection | | yes |
| Measuring/setting range | | |
| Probe length L | [mm] | 55 |
| Liquids | | |
| Setting range | [cm/s] | 3...300 |
| Greatest sensitivity | [cm/s] | 3...100 |
| Gases | | |
| Setting range | [cm/s] | 200...3000 |
| Greatest sensitivity | [cm/s] | 200...800 |
| Accuracy / deviations | | |
| Repeatability | [cm/s] | 1...5 |
| Note on repeatability | | for water 5...100 cm/s; 25 °C Factory setting |
| Temperature drift | [cm/s x 1/K] | 0.1; (for water 5...100 cm/s; 10...70 °C) |
| Max. temperature gradient of medium | [K/min] | 300 |
| Switch point accuracy | [cm/s] | ± 2...± 10; (for water 5...100 cm/s; 25 °C; Factory setting) |
| Hysteresis | [cm/s] | 2...5; (for water 5...100 cm/s; 25 °C; Factory setting) |
| Reaction times | | |
| Response time | [s] | 1...10 |

SI6800



Flow monitor

SIR11ABBFPKG/US-100-IPF

| Liquids | | |
|---|-------------------|---|
| Response time | [s] | 1...10 |
| Gases | | |
| Response time | [s] | 1...10 |
| Software / programming | | |
| Adjustment of the switch point | | pushbuttons |
| Operating conditions | | |
| Ambient temperature | [°C] | -25...60 |
| Protection | | IP 67; IP 69K |
| Tests / approvals | | |
| EMC | DIN EN 61000-6-2 | |
| | DIN EN 61000-6-3 | |
| Shock resistance | DIN EN 60068-2-27 | 50 g (11 ms) |
| Vibration resistance | DIN EN 60068-2-6 | 10 g (55...2000 Hz) |
| MTTF | [years] | 298 |
| Mechanical data | | |
| Weight | [g] | 440 |
| Material | | stainless steel (1.4404 / 316L); PC; PBT-GF20; EPDM/X; sealing: FKM |
| Materials (wetted parts) | | stainless steel (1.4435 / 316L); surface characteristics: Ra < 0,4 / Rz 4 |
| Process connection | | G 1 Aseptoflex Vario |
| Displays / operating elements | | |
| Display | Function | 10 x LED, three-color |
| Remarks | | |
| Pack quantity | | 1 pcs. |
| Electrical connection | | |
| Connector: 1 x M12; coding: A; Contacts: gold-plated | | |
|  | | |

SI6800



Flow monitor

SIR11ABBFPKG/US-100-IPF

Connection

